

Technical Data Sheet

Astro HPE Sealant

UIC of product-type: AFHPE

Revision 13 - 22nd February 2024





ETA-Danmark A/S
Göteborg Plads 1
DK-2150 Nordhavn
Tel. +45 72 24 59 00
Internet www.etadanmark.dk

Authorised and notified
according to Article 29 of the
Regulation (EU)
No 305/2011 of the European
Parliament and of the Council
of 9 March 2011

MEMBER OF EOTA



European Technical Assessment ETA-20/1090 of 2023/11/23

I General Part

Technical Assessment Body issuing the ETA and designated according to Article 29 of the Regulation (EU) No 305/2011: ETA-Danmark A/S

Trade name of the construction product:

ASTRO HPE Sealant

Product family to which the above construction product belongs:

Fire Stopping, Fire Sealing & Fire Protective Products.
Fire Retardant Products

Manufacturer:

Astroflame (fireseals) Limited
Unit 8 The IO Centre
Stephenson Road
Segensworth,
Fareham
Hampshire
PO15 5RU

Manufacturing plant:

E055

This European Technical Assessment contains:

51 pages including 3 annexes which form an integral part of the document

This European Technical Assessment is issued in accordance with Regulation (EU) No 305/2011, on the basis of:

EAD 350454-00-1104 Firestopping and fire sealing products, Penetration Seals

This version replaces:

The ETA with the same number issued on 2020-12-09

Translations of this European Technical Assessment in other languages shall fully correspond to the original issued document and should be identified as such.

Communication of this European Technical Assessment, including transmission by electronic means, shall be in full [except the confidential Annex(es) referred to above]. However, partial reproduction may be made with the written consent of the issuing Technical Assessment Body. Any partial reproduction has to be identified as such.

1 Technical Description of the Product

- 1) ASTRO HPE Sealant is an acrylic based graphite sealant used to reinstate the fire resistance performance of wall and floor constructions where they have been provided with apertures for the penetration of single or multiple services.
- 2) ASTRO HPE Sealant is gun applied to annular space around the service(s) to the required depth (for details see Annex C)
- 3) ASTRO HPE Sealant is supplied in 330ml cartridges and 400ml foils.
- 4) ASTRO HPE Sealant can be installed in conjunction with Astro Batt and coating in accordance with ETA-20/1091

2 Specification of the intended use(s) in accordance with the applicable European Assessment Document (hereinafter EAD)

The intended use of ASTRO HPE Sealant is to reinstate the fire resistance performance of rigid and flexible walls and rigid floor constructions where they are penetrated by various cables, cable trays and plastic and insulated metallic pipes.

- 1) The specific elements of construction that the system ASTRO HPE Sealant may be used to provide a penetration seal in, are as follows:

Rigid walls: The wall must have a minimum thickness of at least 100 mm – as specified in annex C – and comprise concrete, aerated concrete or masonry, with a minimum density of 650 kg/m³.

Rigid floors: The floor must have a minimum thickness of at least 150 mm and comprise concrete, aerated concrete or masonry, with a minimum density of 650 kg/m³.

Flexible walls: The wall must have a minimum thickness of at least 100 mm – as specified in annex C – and comprise timber or steel studs lined on both faces with minimum 2 layers of 12.5 mm thick, gypsum boards according to EN 520. In timber stud walls, no part of the penetration shall be closer than 100 mm to a stud, the cavity must be closed between the penetration seal and the stud and minimum 100 mm of insulation of class A1 or A2 according to EN 13501-1, is provided within the cavity between the penetration seal and the stud.

The supporting construction must be classified in accordance with EN 13501-2 for the required fire resistance period.

- 2) The ASTRO HPE Sealant may be used to provide a penetration seal with plastic and insulated metallic pipes, and cables and cable trays (for details see Annex C).
- 3) The total amount of cross sections of services (including insulation) should not exceed 60% of the penetration area.
- 4) The ASTRO HPE Sealant may be used to seal apertures in the wall separating element up to 100mm wide by 300mm high. The ASTRO HPE Sealant may be used to seal apertures in the floor separating element up to 250mm wide by 250mm high. The minimum permitted separation between adjacent seals/apertures is 200mm.
- 5) Pipes must be installed singular, cables require no minimum separation.
- 6) Services in walls and floors shall be supported at the distances specified in Annex C from the face of the separating element.
- 7) The provisions made in this European Technical Assessment are based on an assumed working life of the ASTRO HPE Sealant of 10 years, provided that the conditions laid down in the product data sheet for the packaging/transport/ storage/installation/use/repair are met. The indications given on the working life cannot be interpreted as a guarantee given by the producer, but are to be regarded only as a means for choosing the right products in relation to the expected economically reasonable working life of the works.

Use Category

Type Z₁: Intended for use in internal conditions with humidity equal to or higher than 85% RH excluding temperatures below 0°C, without exposure to rain or UV.

3 Performance of The Product And References To The Methods Used For Its Assessment

2	Safety in case of fire	
	Reaction to fire	See Clause 3.1.1
	Resistance to fire	See clause 3.1.2
3	Hygiene, Health and the Environment	
	Air permeability	See clause 3.2.1
	Content and release of dangerous substances	See clause 3.2.2
4	Safety and accessibility in use	
	Durability and serviceability	See clause 3.3.1
5	Protection against noise	
	Airborne sound insulation	See clause 3.4

3.1 Safety in case of fire

3.1.1 Reaction to fire

No performance assessed

3.1.2 Resistance to fire

ASTRO HPE Sealant has been tested in accordance with BS EN 1366-3: 2009 based upon the test results and the field of direct application specified within EN 1366-3: 2009, the ASTRO HPE Sealant has been classified in accordance with EN 13501-2, as given in Annex C:

The seals may only be penetrated by the services described in Annex C; other parts or support constructions must not penetrate the seal.

The service support construction must be fixed to the building element containing the penetration seal or a suitable adjacent building element, in such a manner that in the case of fire, no additional load is imposed on the seal. Furthermore it is assumed that the unexposed face support is maintained for the required period of fire resistance.

Pipes must be perpendicular to the seal surface.

It is assumed that compressed air systems are switched off by other means in the case of fire.

The function of the pipe seal in case of pneumatic dispatch systems, pressurized air systems etc. is guaranteed only when the systems are shut off in case of fire.

The assessment does not cover the avoidance of destruction of the seal or of the abutting building element(s) by forces caused by temperature changes in case of fire. This has to be considered when designing the piping system.

The assessment does not address any risks associated with leakage of dangerous liquids or gases caused by failure of the pipe(s) in case of fire.

The durability assessment does not take account of the possible effect of substances permeating through the pipe on the penetration seal.

3.2 Hygiene, Health and the Environment.

3.2.1 Air permeability

ASTRO HPE Sealant has been tested in accordance with EN 1026 to provide the following results:

Product tested	ASTRO HPE sealant			
	Results under positive chamber pressure		Results under negative chamber pressure	
Pressure (Pa)	Leakage (m ³ /h)	Leakage (m ³ /m ² /h)	Leakage (m ³ /h)	Leakage (m ³ /m ² /h)
50	0.2	5.6	0.3	8.3
100	0.4	11.1	0.6	16.7
150	0.7	19.4	0.9	25.0
200	1.0	27.8	1.2	33.3
250	1.1	30.6	1.6	44.4
300	1.2	33.3	1.9	52.8
450	2.2	61.1	2.7	75.0
600	2.4	66.7	3.4	94.4

3.2.2. Content and release of Dangerous Substances

The applicant has presented a declaration that Astro Batt and Coating is in compliance with Council Directive 76/769/EEC of 27th July 1976 on the approximation of the laws, regulations and administrative provisions of the Member States relating to restrictions on the marketing and use of certain dangerous substances and preparations (incl. all amendments and adaptations).

Confirmation has further been declared that all dangerous chemical substances ≥ 1.0 % w/w as well as all toxic, carcinogenic, toxic for reproduction and mutagenic chemical substances ≥ 0.1 % w/w (Status: 29. adaption – 2004/73/EG – of the EU directive 67/548/EEC - classification, packaging and labelling of dangerous substances) are stated in the Astro Batt and Coating material safety data sheets (according to 91/155/EEC including amendments) and have been considered for the classification of the products according to the directive 1999/45/EG (classification of preparations, including amendments).

All dangerous chemical substances are below the classification limits of 67/548/EEC.

In addition to the specific clauses relating to dangerous substances contained in this European technical approval, there may be other requirements applicable to the products falling within its scope (e.g. transposed European legislation and national laws, regulations, and administrative provisions). In order to meet the provisions of the Construction Products Regulation, these requirements need also to be complied with, when and where they apply.

3.3 Safety and accessibility in use

3.3.1 Durability

ASTRO HPE SEALANT has been tested in accordance with EOTA Technical Report - TR024 – EAD 350454-00-1104 – Firestopping and fire sealing products – Penetration Seals, for the type X, and the results of the tests have demonstrated suitability for penetration seals intended for use in conditions exposed to weathering.

3.4 Protection against noise

3.4.1 The results of the test provided the following single number rating:

$R_w(C:Ctr)=52(-1;-6)$

4 Assessment and verification of constancy of performance (hereinafter AVCP) system applied, with reference to its legal base

According to the decision 1999/454/EC of the European Commission the system of assessment and verification of constancy of performance (see Annex V to the Regulation (EU) No 305/2011) given in the following table apply:

Products	Intended use(s)	AVCP System
Fire stopping and fire sealing products	For fire compartmentation and / or fire protection or fire performance	System 1

5 Technical details necessary for the implementation of the AVCP system, as provided for in the applicable EAD

Technical details necessary for the implementation of the AVCP system are laid down in the control plan deposited at ETA-Danmark A/S prior to CE marking

Issued in Copenhagen on 2023-xx-xx by



Thomas Bruun

Managing Director, ETA-Danmark

Annex A

Reference Documents

EN 13501-1	Fire classification of construction products and building elements – Part 1: Classification using test data from reaction to fire tests
EN 13501-2	Fire classification of construction products and building elements – Part 2: Classification using test data from fire resistance tests
EOTA TR 024	Characterisation, Aspects of Durability and Factory Production Control for Reactive Materials, Components and Products

Annex B

Description of Product

ASTRO HPE Sealant

A detailed specification of the product is held on file by ETA-Danmark A/S

Annex C Resistance to fire classifications

C.1 Flexible or Rigid Walls Minimum Thickness 100 mm

C.1.1 Plastic pipes

Flexible or Rigid Walls ≥ 100 mm				
				<p><u>Key</u></p> <ol style="list-style-type: none"> 1. ASTRO HPE Sealant 2. Plastic pipe 3. Flexible wall
Penetration Service	Depth (mm)	Annular Space (mm)	Backing Material	Classification
PVC pipe 40 – 125 mm \varnothing , 1.9 – 9.2 mm wall thickness*	25 (with 10 mm fillet protruding wall)	20	N/A	EI 45 C/U, U/C, C/C
PVC pipe 40 mm \varnothing , 1.9 mm wall thickness				EI 120 - C/U, U/C, C/C
ABS pipe 40 mm \varnothing , 1.9 mm wall thickness				EI 120 - C/U, U/C, C/C
PP pipe 40 mm \varnothing , 2 mm wall thickness				EI 120 - C/U, U/C, C/C

*Typical pipe diameters shown, see below graph for intermediate sizes

All services supported with 'Unistrut' pipe supports at 260 mm from both faces of the wall.

PVC-U Pipes - EI 45 C/U

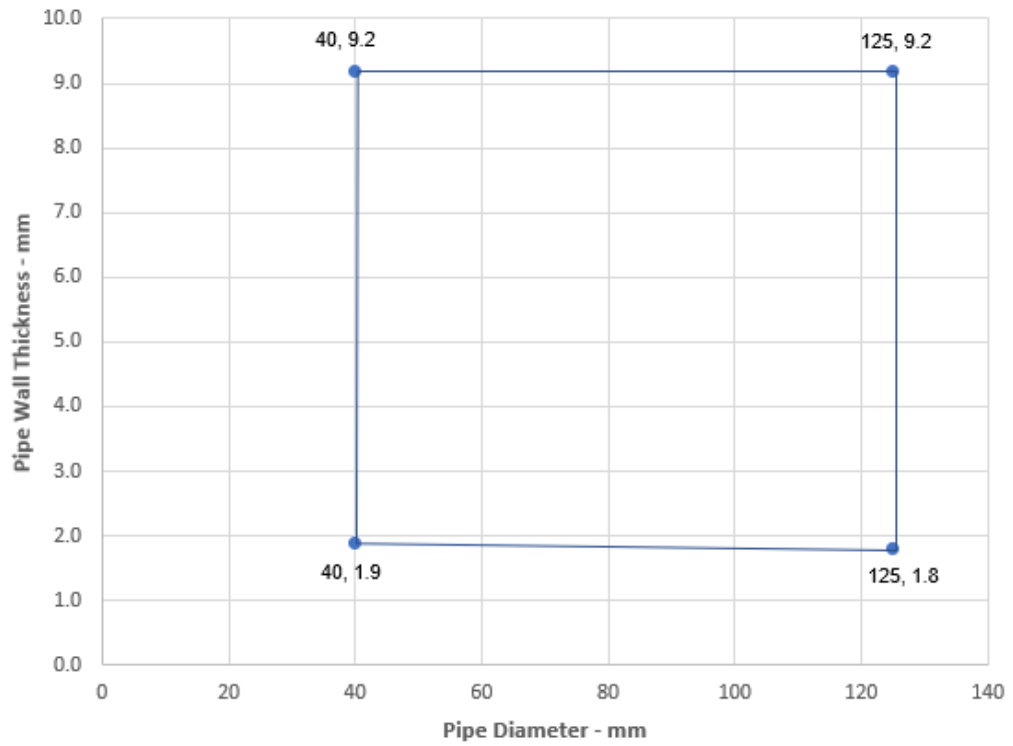

Flexible or Rigid Walls ≥ 100 mm

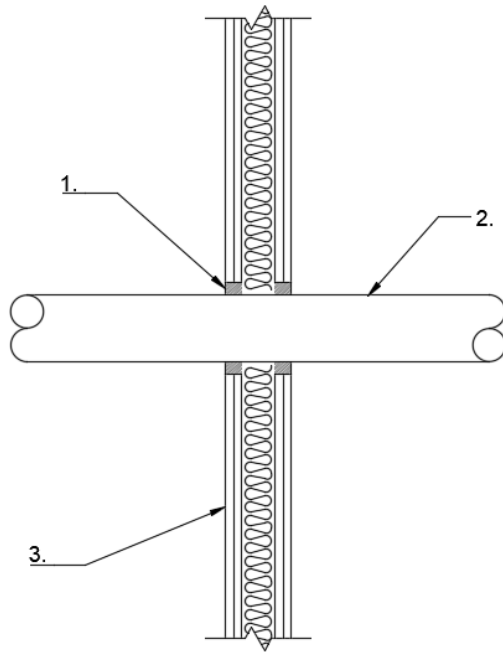

Key

1. ASTRO HPE Sealant
2. Plastic pipe
3. Flexible wall

Penetration Service	Depth (mm)	Annular Space (mm)	Backing Material	Classification
Blazemaster CPVC Sprinkler Pipe 27 – 89 mm \varnothing , 2.5 – 7.2 mm wall thickness	25	20	N/A	EI 120 – U/U, C/U, U/C, C/C

All services supported with pipe and cable supports at 425 mm from both faces of the wall.

Flexible or Rigid Walls ≥ 100 mm				
			<p><u>Key</u></p> <ol style="list-style-type: none"> 1. ASTRO HPE Sealant 2. Plastic pipe 3. Astro Batt and Coating 4. Flexible Wall 	
Penetration Service	ASTRO HPE Sealant		Astro Batt and Coating Maximum Aperture Size (mm)	Classification
	Annular Space (mm)	Min. Depth (mm)		
Lubrizol CPVC Sprinkler Pipe 20 – 80 mm \varnothing , 2.5 – 7.9 mm wall thickness	20	25	1200 x 730	EI 90 – C/U, U/C, C/C
			2600 x 2600	EI 60 – C/U, U/C, C/C

All services supported with pipe and cable supports at 425 mm from both faces of the wall.

Flexible or Rigid Walls ≥ 100 mm Insulated or uninsulated

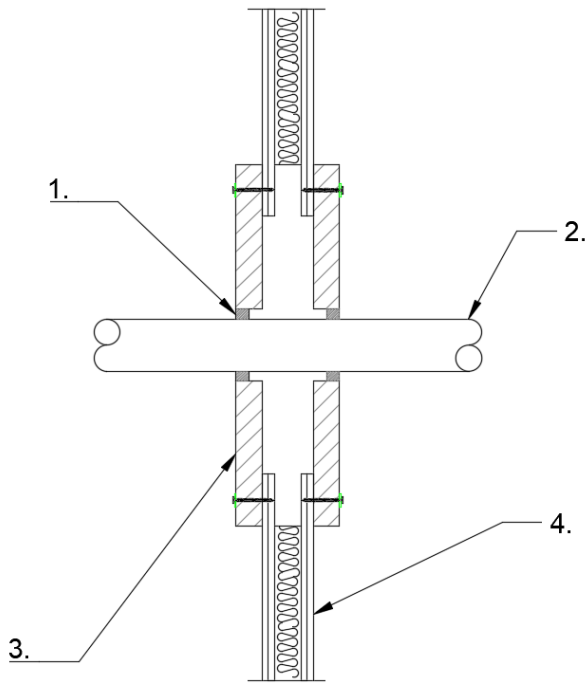

Key

1. ASTRO HPE Sealant
2. Plastic pipe
3. Astro Batt and Coating
4. Flexible Wall

Penetration Service	ASTRO HPE Sealant		Astro Batt and Coating Maximum Aperture Size (mm)	Classification
	Annular Space (mm)	Min. Depth (mm)		
Blazemaster CPVC Sprinkler Pipe 27 – 89 mm \varnothing , 2.5 – 7.0 mm wall thickness	20	25	1200 x 750	EI 120 – U/C, C/U, U/C, C/C

All services supported with pipe and cable supports at 425 mm from both faces of the wall.

C.1.2 Cables, Metallic Pipes, Insulated metallic pipes

Flexible or Rigid Walls ≥100 mm				
				<p><u>Key</u></p> <ol style="list-style-type: none"> 1. ASTRO HPE Sealant 2. Insulated metal pipe 3. Flexible wall
Penetration Service	Depth (mm)	Annular Space (mm)	Backing Material	Classification
Copper 159 mm Ø, 2 -14.2 mm wall thickness with ≥30 mm thick ≥80kg/m ³ foil faced glass wool (LS*, CS**)	25 (with 10 mm fillet protruding wall)	20	N/A	E 120, EI 30 – C/U, C/C
Copper 40 – 159 mm Ø, 2 -14.2 mm wall thickness with 32 mm thick 96kg/m ³ Armaflex pipe insulation (LS*, CS**)				

All services supported with 'Unistrut' pipe supports at 260 mm from both faces of the wall.

* Continuous through seal and extending minimum 650 mm from both faces of the seal (LS)

** Continuous through seal and full length of the pipe (CS)

Flexible or Rigid Walls ≥ 100 mm

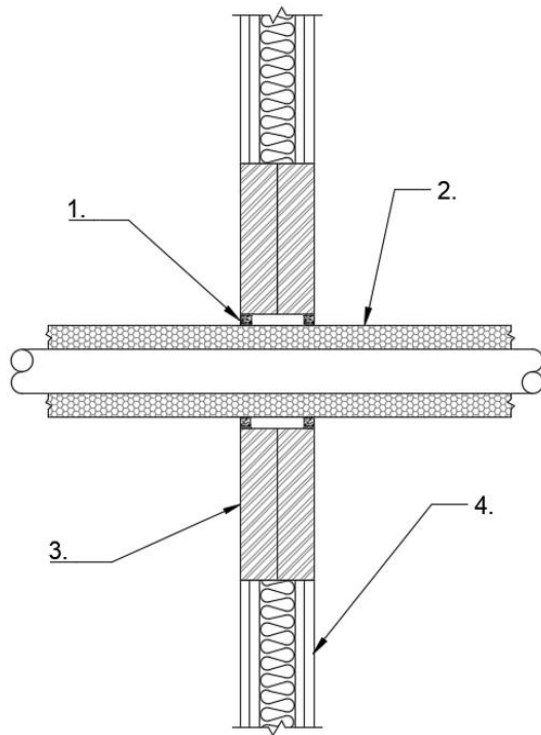

Key

1. ASTRO HPE Sealant
2. Insulated metal pipe
3. Astro Batt and Coating
4. Flexible wall

Penetration Service	ASTRO HPE Sealant		Astro Batt and Coating Maximum Aperture Size (mm)	Classification
	Annular Space (mm)	Min. Depth (mm)		
Copper/Steel pipe 40 mm \varnothing 1.5 mm – 14.2 mm wall thickness, insulated with ≥ 20 mm thick foil faced glass wool insulation $\geq 80\text{kg/m}^3$ (CS) Continued Sustained	15	15	2600 x 2600	EI 60 - C/C
Copper/Steel pipe 40mm – 159mm \varnothing 1.5mm – 14.2 mm wall thickness*, insulated with ≥ 30 mm thick foil faced glass wool insulation $\geq 80\text{kg/m}^3$ (CS) Continued Sustained	15	15	1200 x 730	EI 60 - C/C

*Typical pipe diameters shown, see below graph for intermediate sizes

All services supported with pipe and cable supports at 250 mm from both faces of the wall.

Copper or Steel Pipes with Glass Wool Insulation EI 60 C/C

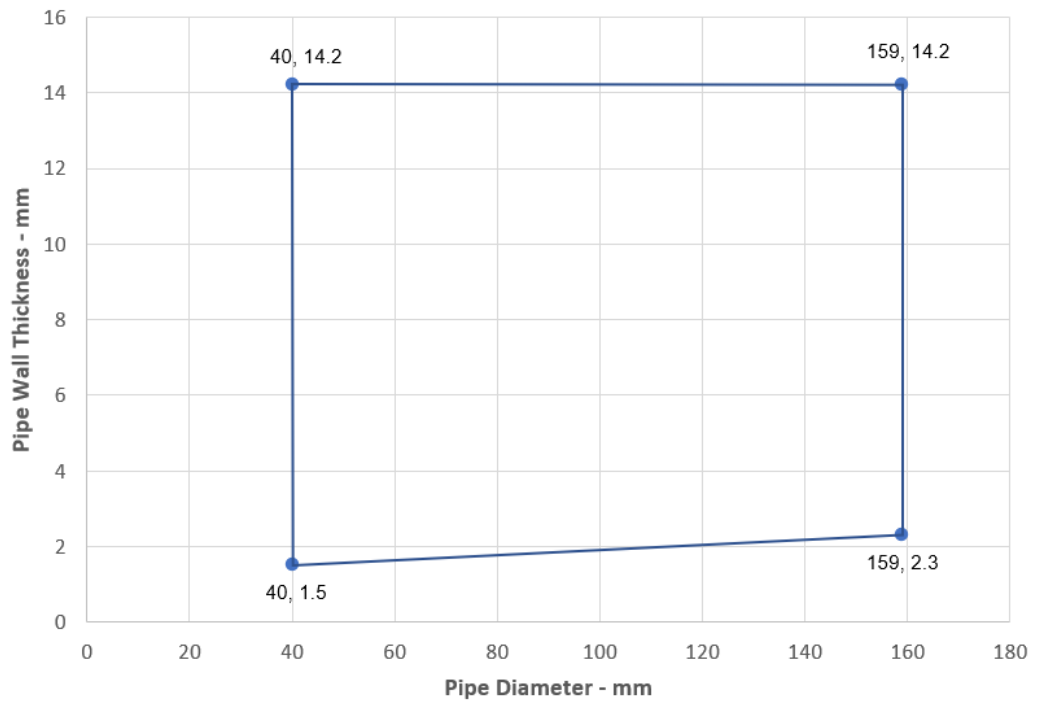

Flexible or Rigid Walls ≥ 100 mm Insulated or uninsulated

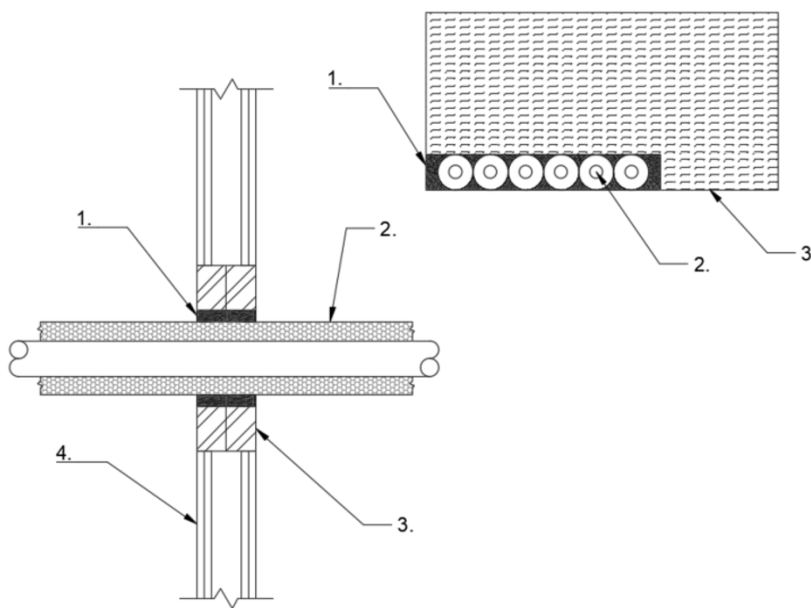

Key

1. ASTRO HPE Sealant
2. Insulated metal pipe
3. Astro Batt and Coating
4. Flexible wall

Penetration Service	ASTRO HPE Sealant		50 mm Astro Batt and Coating Maximum Aperture Size (mm)	Separating Distance		Classification
	Annular Space (mm)	Min. Depth (mm)		Between Services	Aperture Edge	
6x $\varnothing 22$ mm, 0.9 mm - 14.2mm wall thickness Copper pipes with 20 mm thick Kooltherm FM insulation (LS*, CS**)	0mm above and below service, 20 mm on each side of service	full depth	Double layer 2600 mm x 2600 mm	≥ 0 mm	≥ 0 mm	EI 30 - C/U, C/C
6x $\varnothing 22$ mm, 0.9-14.2 mm wall thickness Copper pipes with 19 mm thick Armaflex Class 'O' insulation (LS*, CS**)						E 90, EI 60 - C/U, C/C

All services supported with 'Unistrut' pipe and cable supports at 400 mm from both faces of the wall.

* Continuous through seal and extending minimum 450 mm from both faces of the seal (LS)

** Continuous through seal and full length of the pipe (CS)

C.2 Flexible or Rigid Walls Minimum Thickness 120 mm

C.2.1 Plastic pipes

Flexible or Rigid Walls ≥ 120 mm				
				<p><u>Key</u></p> <ol style="list-style-type: none"> 1. Astro HPE Sealant 2. Plastic pipe 3. Flexible Wall
Penetration Service	Depth (mm)	Annular Space (mm)	Backing Material	Classification
PVC pipe 40 – 125 mm \varnothing , 1.9 – 7.4 mm wall thickness*	25	16	≥ 30 mm deep $\geq 80\text{kg/m}^3$ Stone wool	EI 120 - U/C, C/C

*Typical pipe diameters shown, see below graph for intermediate sizes

All services supported with 'Unistrut' pipe supports at 150 mm from both faces of the wall.

PVC-U Pipes - EI 120 U/C

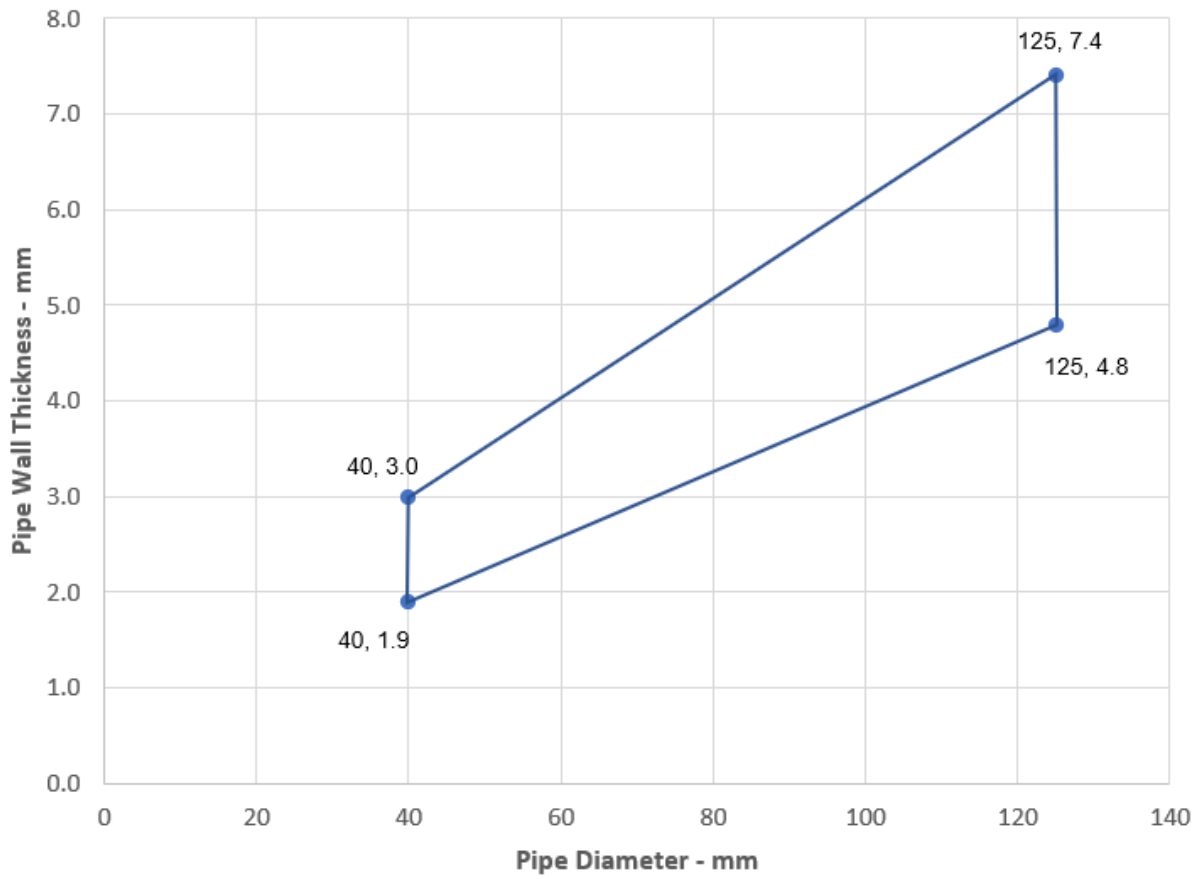

Flexible or Rigid Walls ≥ 120 mm					
					<p><u>Key</u></p> <ol style="list-style-type: none"> 1. ASTRO HPE Sealant 2. Plastic pipe 3. Flexible Wall
Penetration Service	Depth (mm)	Maximum Aperture Size (mm)	Annular Space (mm)	Backing Material	Classification
HDPE pipe 63 mm \varnothing 7.2 mm wall thickness	25	300 x 100	12.5	n/a	EI 120 - U/C, C/C

All services supported with 'Unistrut' pipe supports at 150 mm from both faces of the wall.

Flexible or Rigid Walls ≥ 120 mm				
				<p><u>Key</u></p> <ol style="list-style-type: none"> 1. ASTRO HPE Sealant 2. Plastic pipe 3. Flexible Wall
Penetration Service	Depth (mm)	Annular Space (mm)	Backing Material	Classification
HDPE pipe 90 mm \varnothing 9.2 mm wall thickness	25	12.5	n/a	EI 120 - U/C, C/C

All services supported with 'Unistrut' pipe and cable supports at 150 mm from both faces of the wall.

Flexible or Rigid Walls ≥ 120 mm

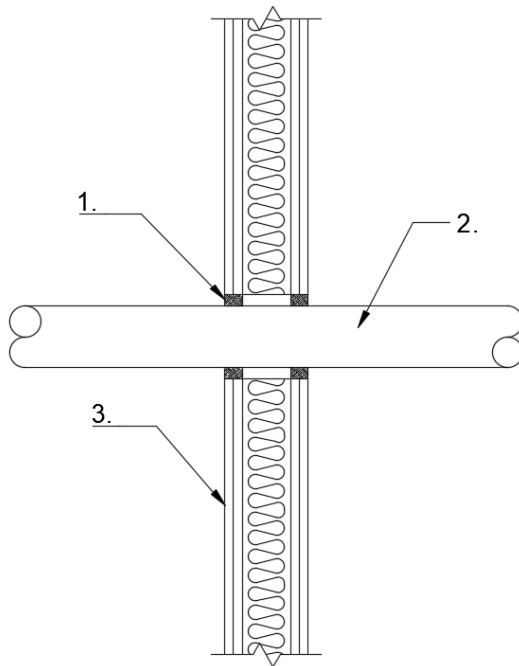

Key

- 1. ASTRO HPE Sealant
- 2. Plastic pipe
- 3. Flexible Wall

Penetration Service	Depth (mm)	Annular Space (mm)	Backing Material	Classification
ABS pipe 90 mm \varnothing 6.0 mm wall thickness	25	12.5	n/a	EI 120 - U/C, C/C

All services supported with 'Unistrut' pipe and cable supports at 150 mm from both faces of the wall.

C.2.2 Insulated metallic pipes

Flexible or Rigid Walls ≥ 120 mm				
				<p><u>Key</u></p> <ol style="list-style-type: none"> 1. ASTRO HPE Sealant 2. Plastic pipe 3. Flexible Wall 4. Armaflex Insulation
Penetration Service	Depth (mm)	Annular Space (mm)	Backing Material	Classification
Copper/Steel pipe 60 mm \varnothing 0.8 mm – 14.2 mm wall thickness, insulated with 32 mm 'Armaflex' Continued Sustained (CS)	25	20	n/a	E 120, E I90 - C/U, C/C
Copper/Steel pipe 15 mm \varnothing 0.8 mm – 7 mm wall thickness, insulated with 13 mm 'Armaflex' Continued Sustained (CS)	25	12	n/a	EI 120 - C/U, C/C

All services supported with 'Unistrut' pipe and cable supports at 150 mm from both faces of the wall.

C.3 Rigid Walls Minimum Thickness 150 mm

C.3.1 Plastic pipes

Rigid Walls ≥ 150 mm				
				<p><u>Key</u></p> <ol style="list-style-type: none"> 1. ASTRO HPE Sealant 2. Plastic pipe 3. Astro Batt and Coating 4. Rigid wall
Penetration Service	ASTRO HPE Sealant		Penetration Seal Maximum Aperture Size (mm)	Classification
	Annular Space (mm)	Min. Depth (mm)		
PVC Pipe 50 mm \varnothing 2.6 wall thickness	20	25 - both sides of wall	1100 x 750	EI 45 - U/C, C/C
PVC Pipe 50 mm \varnothing 2.6 – 3.7 wall thickness	20	25 - both sides of wall	1100 x 750	E 45, EI 30 - U/C, C/C
PVC Pipe 50 mm – 125 mm \varnothing 2.6 – 7.4 wall thickness*	20	25 - both sides of wall	1100 x 750	EI 30 - U/C, C/C

*Typical pipe diameters shown, see below graph for intermediate sizes

All services supported with 'Unistrut' pipe and cable supports at 400 mm from both faces of the wall.

PVC-U Pipes - EI 30 U/C

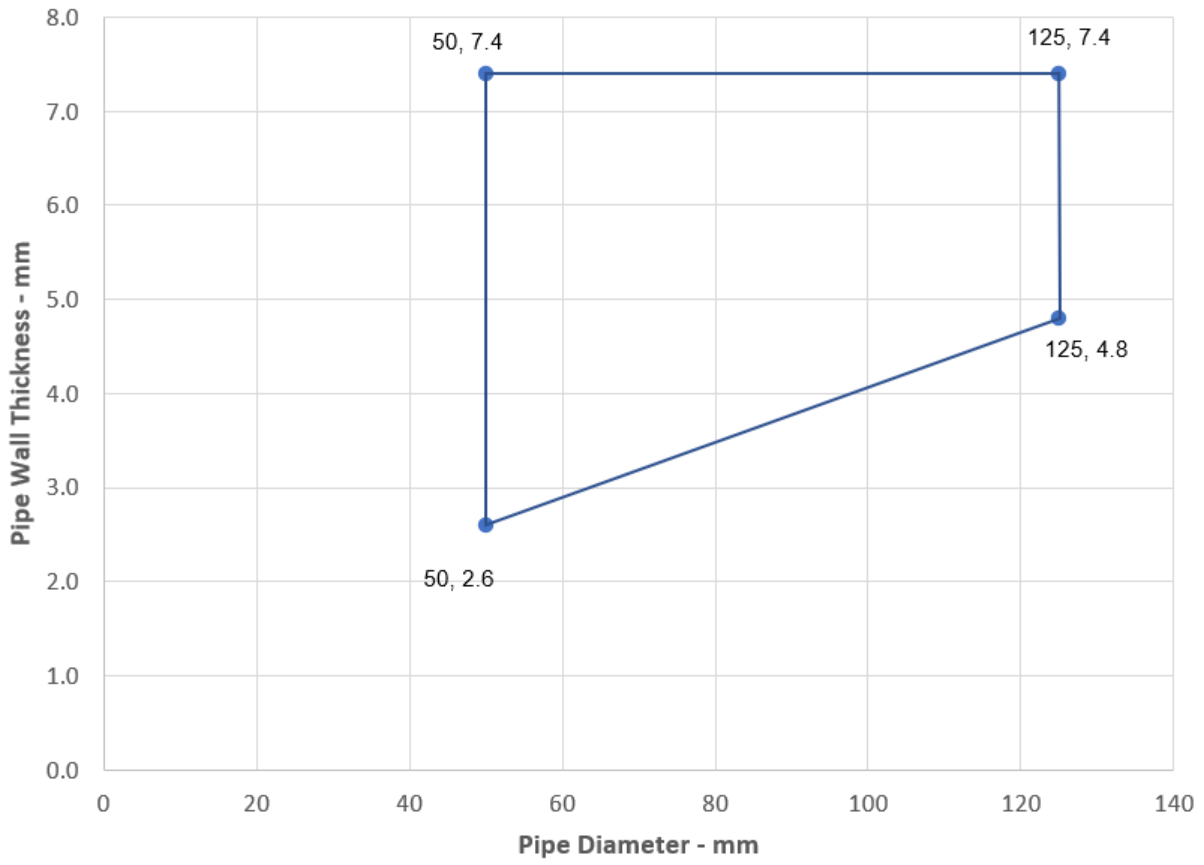

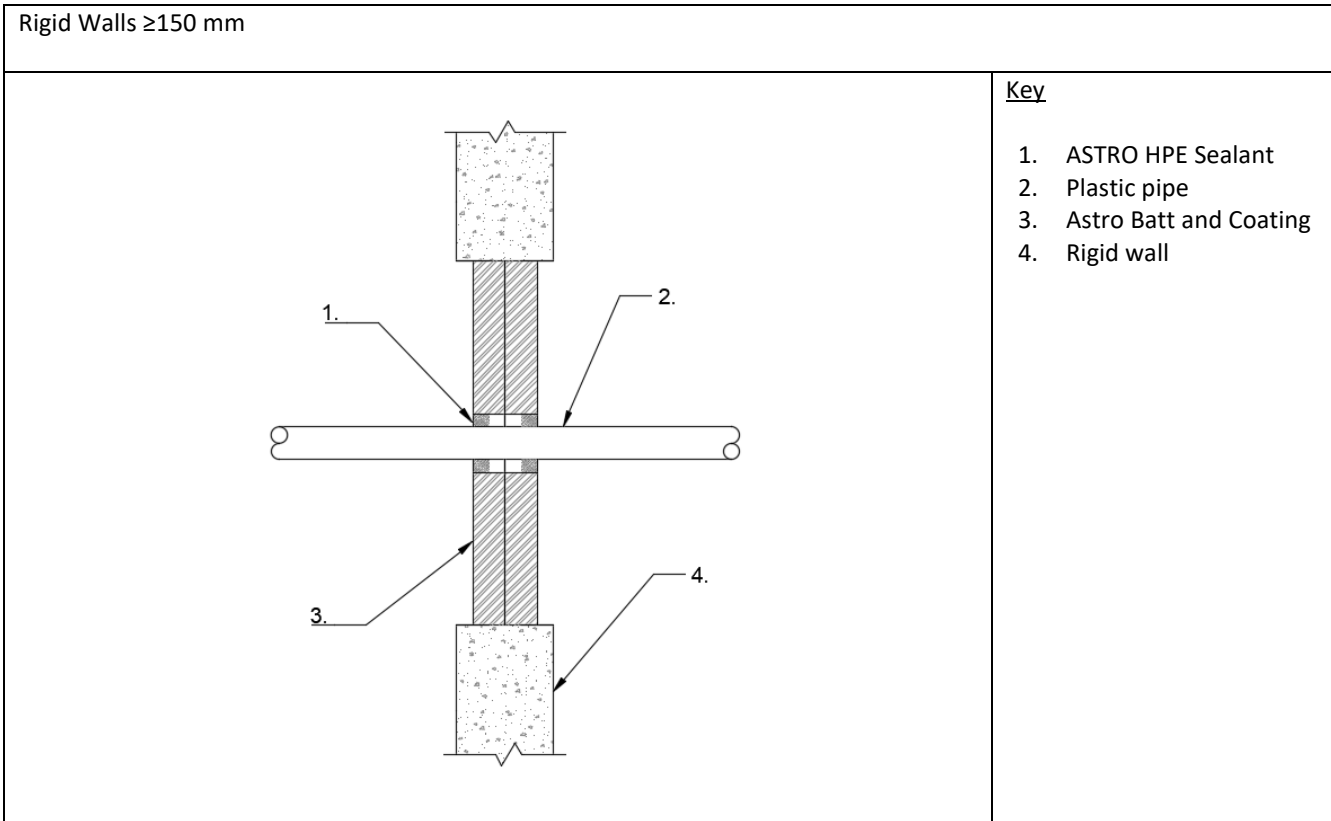

Key

1. ASTRO HPE Sealant
2. Plastic pipe
3. Astro Batt and Coating
4. Rigid wall

Penetration Service	ASTRO HPE Sealant		Penetration Seal Maximum Aperture Size (mm)	Classification
	Annular Space (mm)	Min. Depth (mm)		
PVC Pipe 50 mm \varnothing 2.6 – 7.4 mm wall thickness*	20	25 - both sides of wall	1200 x 730	EI 120 - U/C, C/C
PVC Pipe 125 mm \varnothing 7.4 mm wall thickness				E 120, EI 90 - U/C, C/C
PVC Pipe 50 mm – 125 mm \varnothing 2.6 – 7.4 mm wall thickness*				
PVC Pipe 50 mm \varnothing 2.6 – 7.4 mm wall thickness	20	25 - both sides of wall	2600 x 2600	EI 60 - U/C, C/C
PVC Pipe 125 mm \varnothing 7.4 mm wall thickness				
PVC Pipe 50 mm – 125 mm \varnothing 2.6 – 7.4 mm wall thickness*				

*Typical pipe diameters shown, see below graph for intermediate sizes

All services supported with 'Unistrut' pipe and cable supports at 400 mm from both faces of the wall.

PVC-U Pipes - EI 120 U/C

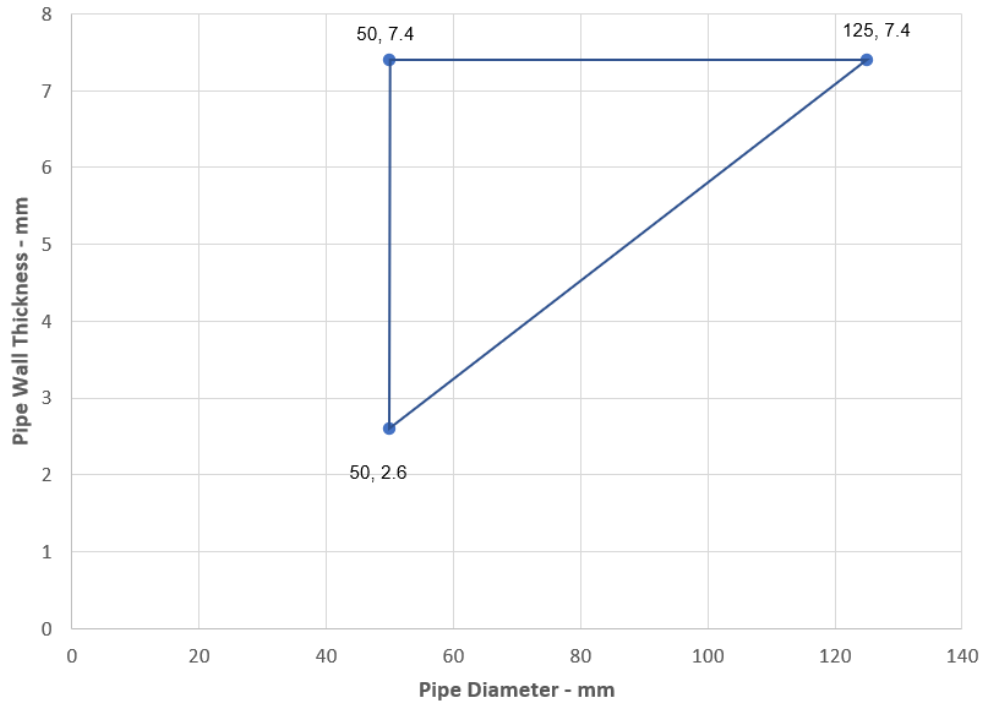

PVC-U Pipes - E 120, EI 90 U/C

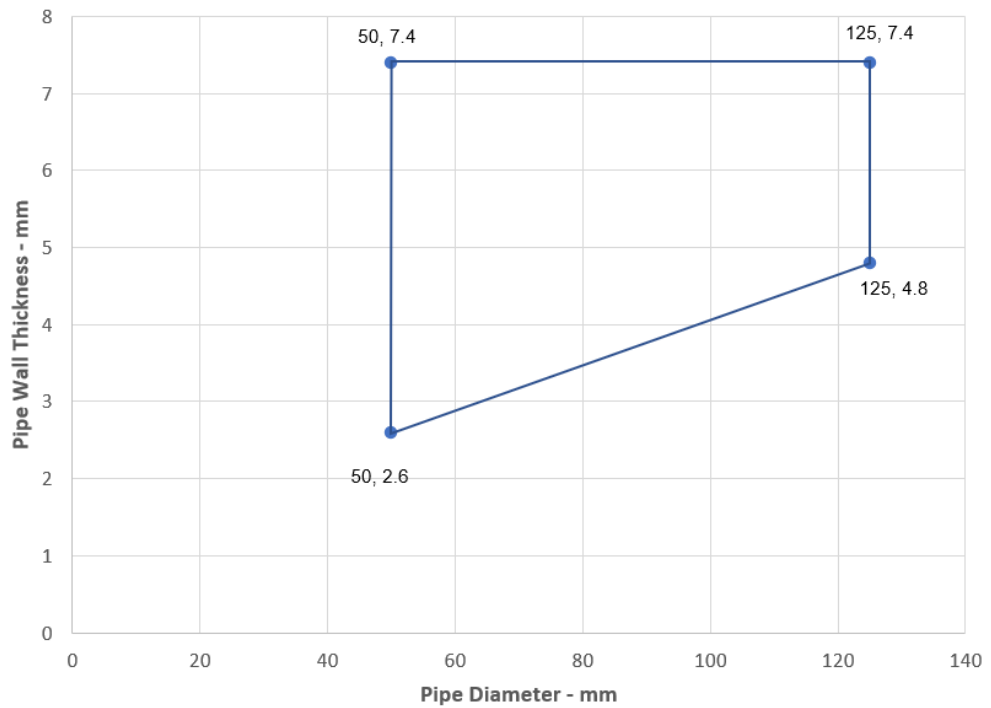

PVC-U Pipes - EI 60 U/C

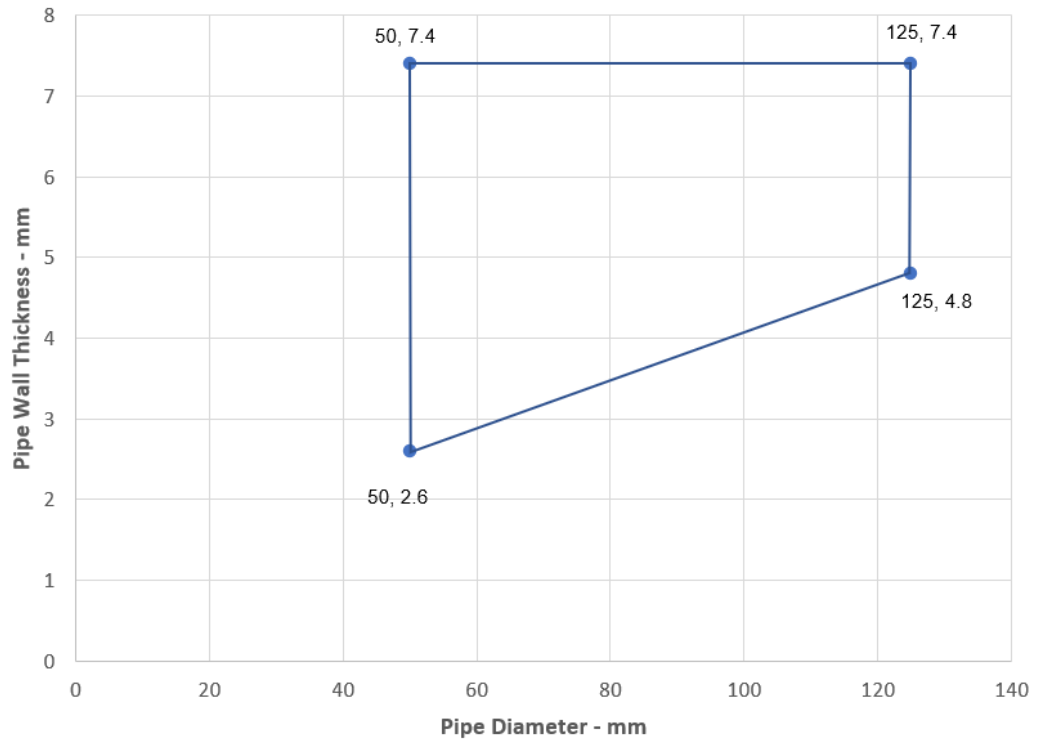

C.3.2 Multi layered pipes

Rigid Walls ≥ 150 mm				
			<p><u>Key</u></p> <ol style="list-style-type: none"> 1. ASTRO HPE Sealant 2. MLC pipe 3. Astro Batt and Coating 4. Rigid wall 	
Penetration Service	ASTRO HPE Sealant		Penetration Seal Maximum Aperture Size (mm)	Classification
	Annular Space (mm)	Min. Depth (mm)		
Uponor MLC (Multi-Layer Composite) Pipe 40 mm – 110 mm \varnothing 4 mm – 10 mm wall thickness*	20	25 - both sides of wall	1100 x 750	E 45, EI30 - C/U, U/C & C/C

*Typical pipe diameters shown, see below graph for intermediate sizes

All services supported with 'Unistrut' pipe and cable supports at 400 mm from both faces of the wall.

MLC Pipes - E 45, EI 30 C/U

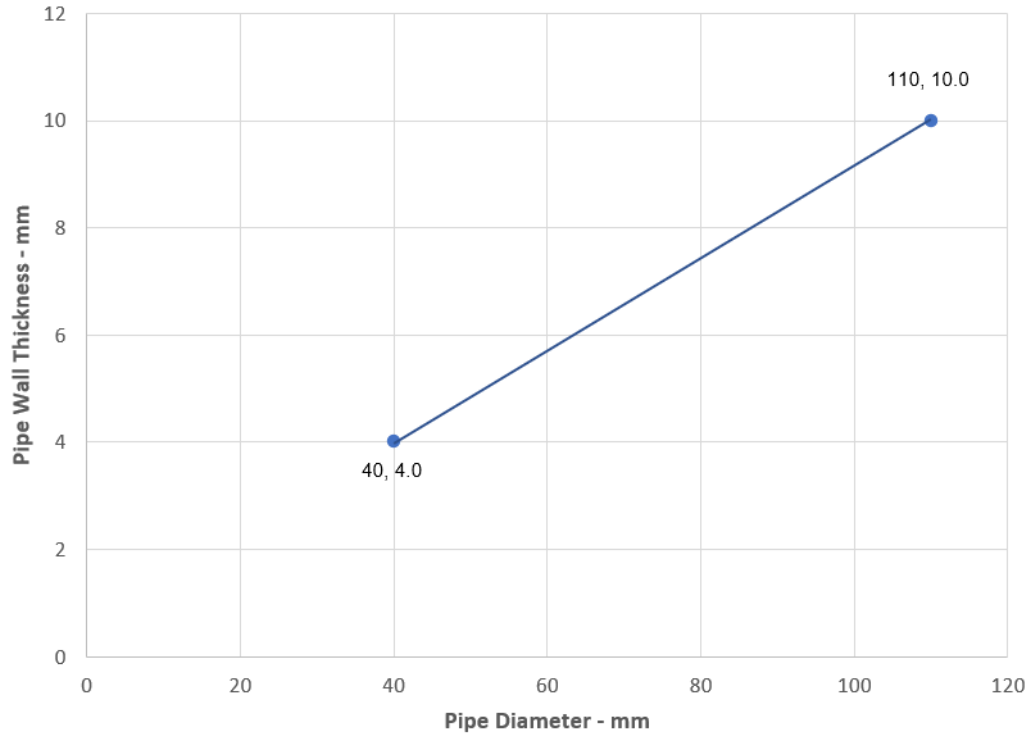

Rigid Walls ≥ 150 mm				
			<p><u>Key</u></p> <ol style="list-style-type: none"> 1. ASTRO HPE Sealant 2. Plastic pipe 3. Astro Batt and Coating 4. Rigid wall 	
Penetration Service	ASTRO HPE Sealant		Penetration Seal Maximum Aperture Size (mm)	Classification
	Annular Space (mm)	Min. Depth (mm)		
Uponor MLC (Multi-Layer Composite) Pipe 40 mm – 110 mm \varnothing 4 mm – 10 mm wall thickness*	20	25 - both sides of wall	1200 x 730	EI 120 – U/C, C/C
			2600 x 2600	EI 60 - U/C, C/C

*Typical pipe diameters shown, see below graph for intermediate sizes

All services supported with 'Unistrut' pipe and cable supports at 400 mm from both faces of the wall.

MLC Pipes - U/C

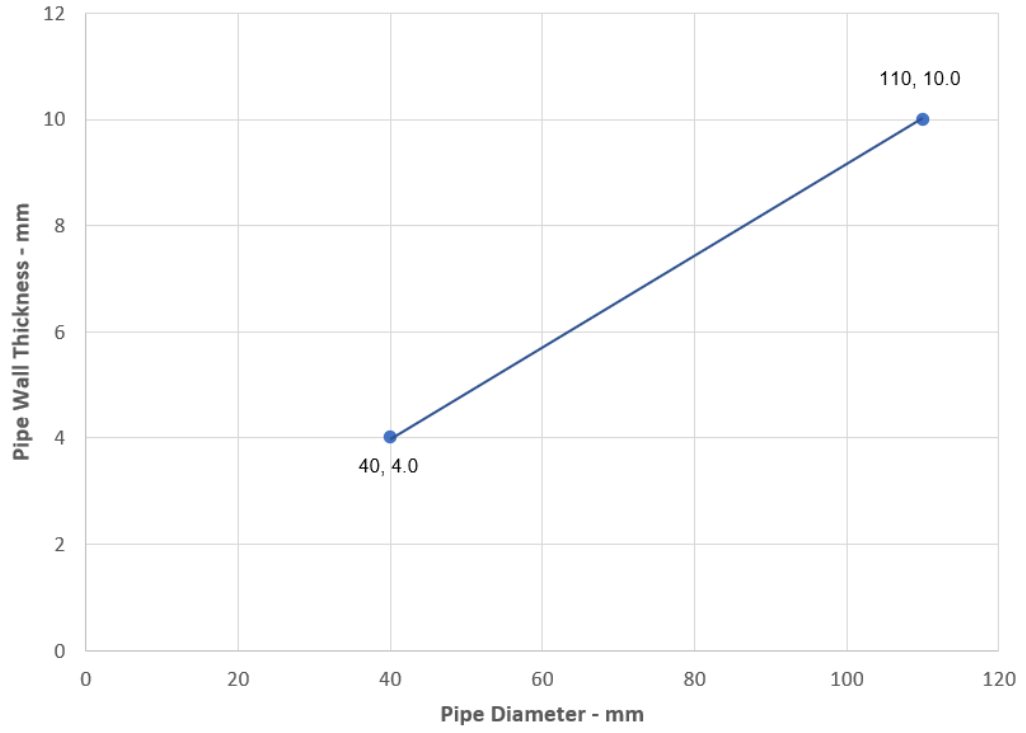

C.3.3 Cables

Rigid Walls ≥ 150 mm					
					<p><u>Key</u></p> <ol style="list-style-type: none"> 1. ASTRO HPE Sealant 2. Backing material 3. Cables 4. Rigid wall
Penetration Service	Depth (mm)	Maximum Aperture Size (mm)	Backing Material	Minimum Distance to Edge of Aperture (mm)	Classification
Telecomms. Cable bunch ≤ 100 mm \varnothing	25	180 x 180	Stone wool or ceramic wool (20mm 45kg/m ³)	10	EI 240
PVC conduits ≤ 16 mm \varnothing					E 240, EI 45
Steel/Copper conduits ≤ 16 mm \varnothing					E 240, EI 90
Cables ≤ 21 mm \varnothing					E 180, EI 45
Cables ≤ 50 mm \varnothing					E 180, EI 45
Cables ≤ 80 mm \varnothing					E 180, EI 45

All services supported with 'Unistrut' pipe and cable supports at 400 mm from both faces of the wall.

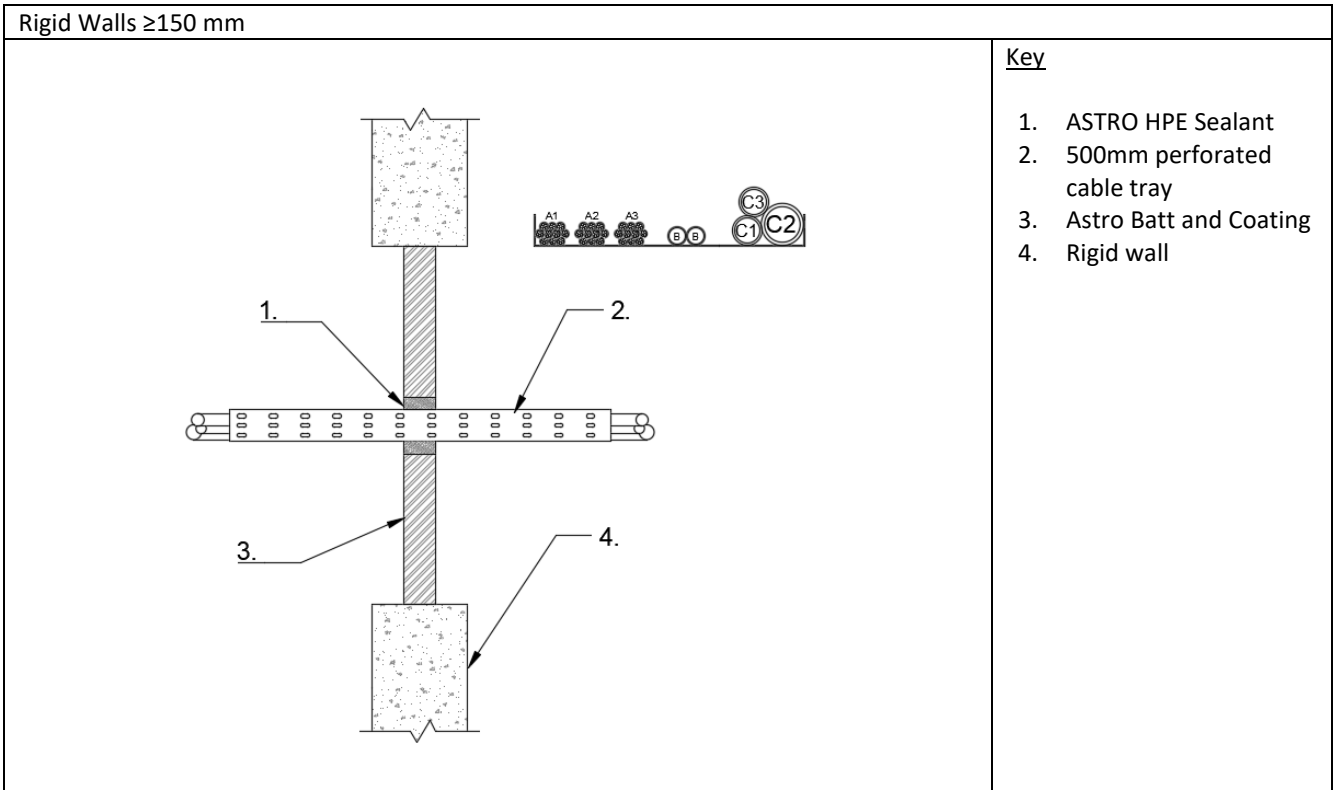

Penetration Service	ASTRO HPE Sealant		Penetration Seal Maximum Aperture Size (mm)	Classification
	Annular Space (mm)	Min. Depth (mm)		
*500 mm perforated cable tray	20	25 - both sides of wall	1100 x 750	EI 30
*Electrical cables up to 21 mm \varnothing				
Cable bunch comprising 1no. C1, 1no. C2 and 1no. C3 cables				

*All cables coated with 2mm DFT PST Coating 300mm along the cables both sides of the seal

All services supported with pipe and cable supports at 400 mm from both faces of the wall.

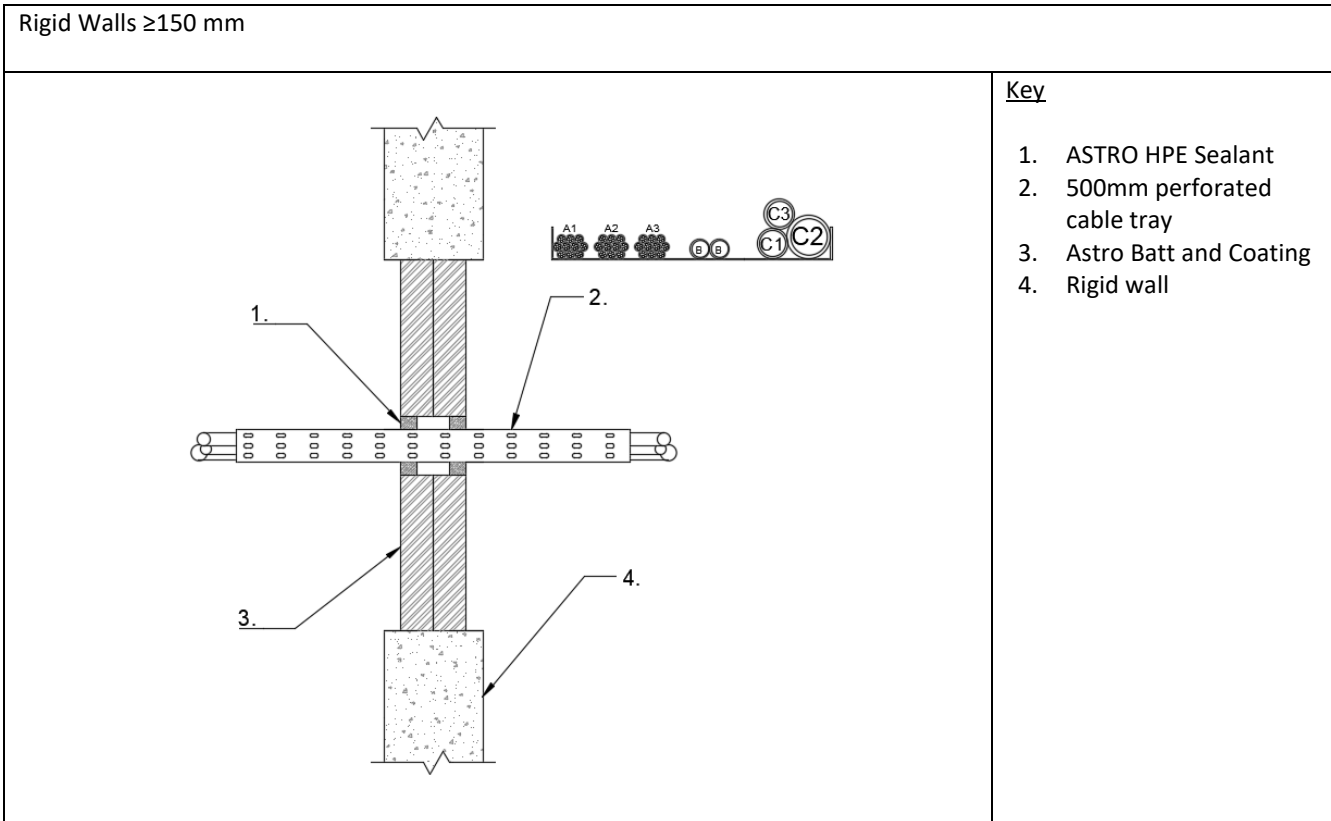

Penetration Service	ASTRO HPE Sealant		Penetration Seal Maximum Aperture Size (mm)	Classification
	Annular Space (mm)	Min. Depth (mm)		
*500 mm perforated cable tray	20	25 - both sides of wall	1200 x 730	EI 120
*Electrical cables up to 21 mm \varnothing				E 120, EI 90
*Cable bunch comprising 1no. C1, 1no. C2 and 1no. C3 cables			2600 x 2600	EI 60
*500 mm perforated cable tray				
*Electrical cables up to 50 mm \varnothing				

*All cables coated with 2mm DFT PST Coating 300mm along the cables both sides of the seal

All services supported with pipe and cable supports at 400 mm from both faces of the wall.

C.3.4 Metallic pipes

Rigid Walls ≥ 150 mm				
			<p><u>Key</u></p> <ol style="list-style-type: none"> 1. ASTRO HPE Sealant 2. Metal pipe 3. Astro Batt and Coating 4. Rigid wall 	
Penetration Service	ASTRO HPE Sealant		Penetration Seal Maximum Aperture Size (mm)	Classification
	Annular Space (mm)	Min. Depth (mm)		
Copper/Steel pipe 40 mm – 159mm \varnothing 1.2mm – 14.2 mm wall thickness*	20	25 - both sides of wall	1100 x 750	E 45, EI 20 – C/U, C/C
Copper/Steel pipe 40 mm \varnothing 1.2mm – 14.2 mm wall thickness				EI 45 - C/U, C/C

*Typical pipe diameters shown, see below graph for intermediate sizes

All services supported with 'Unistrut' pipe and cable supports at 400 mm from both faces of the wall.

Copper Pipes - C/U

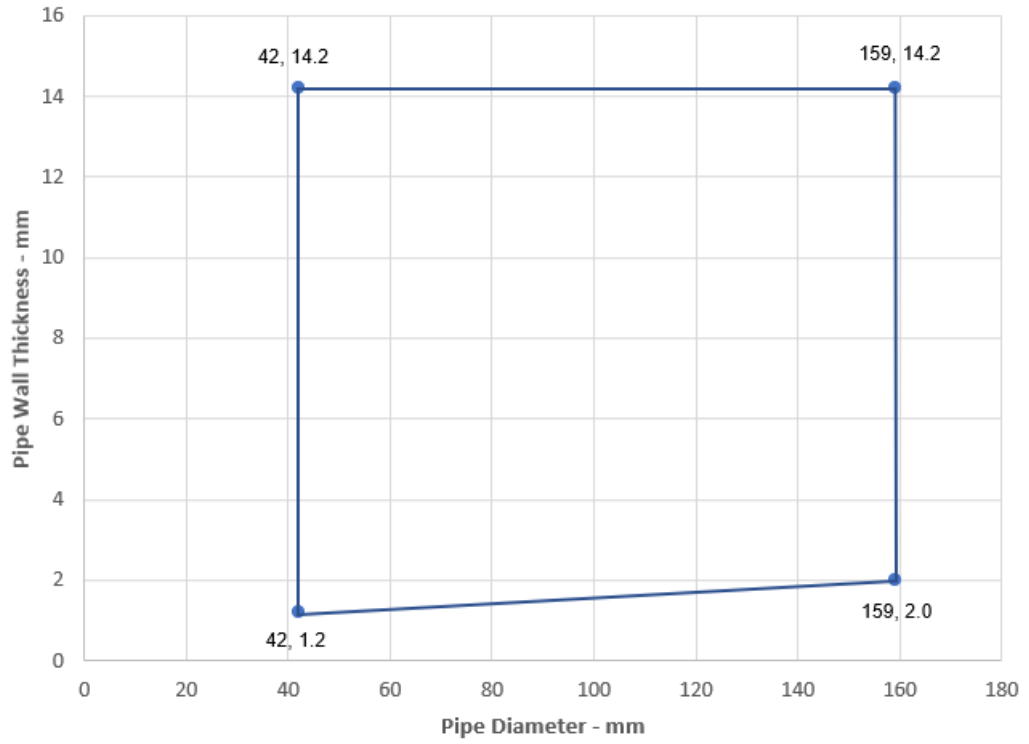

Rigid Walls ≥ 150 mm

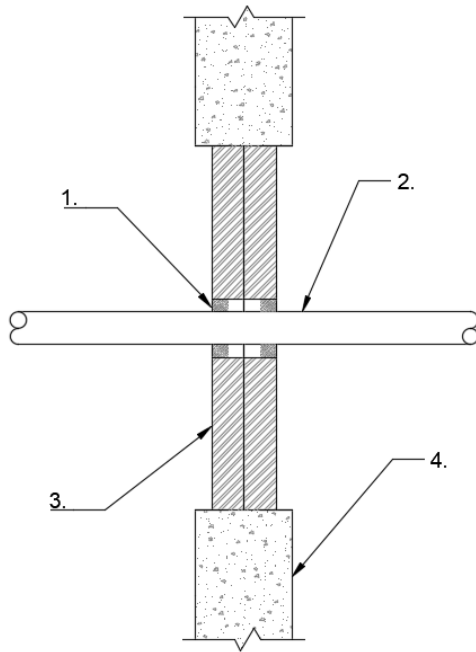

Key

1. ASTRO HPE Sealant
2. Metal pipe
3. Astro Batt and Coating
4. Rigid wall

Penetration Service	ASTRO HPE Sealant		Penetration Seal Maximum Aperture Size (mm)	Classification
	Annular Space (mm)	Min. Depth (mm)		
Copper/Steel pipe 42 mm – 159mm \varnothing 1.2mm – 14.2 mm wall thickness*	20	25 - both sides of wall	1100 x 750	E 120, EI 30 – C/U, C/C
Copper/Steel pipe 42 mm \varnothing 1.2 mm – 14.2 mm wall thickness				E 120, EI 60 – C/U, C/C
Copper/Steel pipe 42 mm – 159 mm \varnothing 1.2 mm – 14.2 mm wall thickness			2600 x 2600	EI 60 – C/U, C/C

*Typical pipe diameters shown, see below graph for intermediate sizes

All services supported with pipe and cable supports at 400 mm from both faces of the wall.

Copper Pipes - C/U

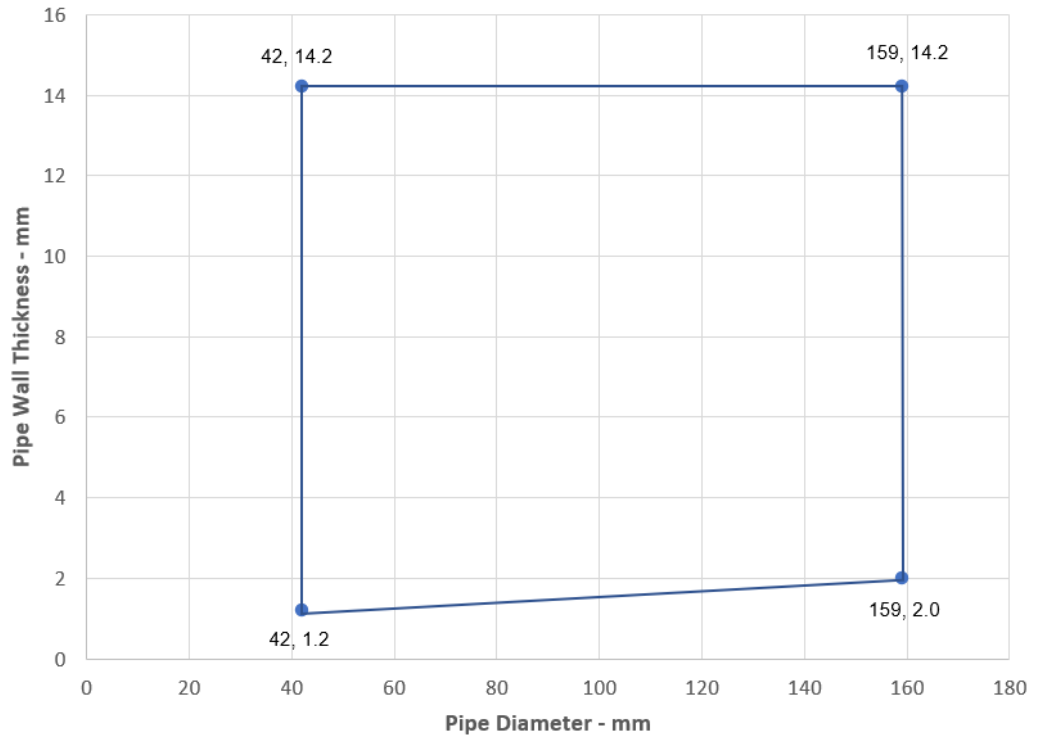

C.4 Rigid Floors Minimum Thickness 150 mm

C.4.1 Plastic pipes

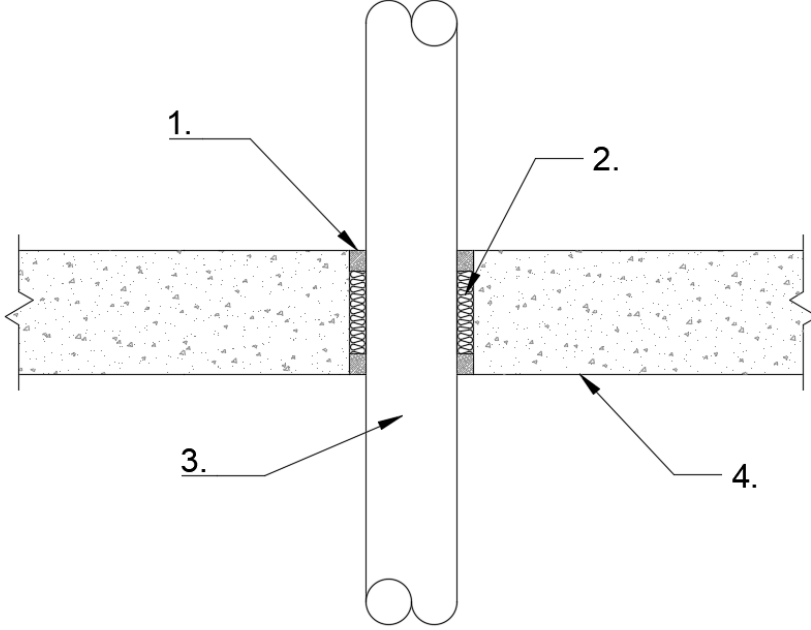
Flexible Floor $\geq 150\text{mm}$				
				<p><u>Key</u></p> <ol style="list-style-type: none"> 1. ASTRO HPE Sealant 2. Backing material 3. Plastic pipe 4. Rigid floor
Penetration Service	ASTRO HPE Sealant Depth (mm)	Annular Space (mm)	Backing Material	Classification
PP Pipe 110 mm \emptyset 3.7 mm wall thickness	≥ 25 (both sides of floor)	20mm	$\geq 100\text{mm}$ $\geq 45 \text{ kg/m}^3$ stone wool	EI 30 - U/C, C/C
PP Pipe 110 mm \emptyset 10.7 mm wall thickness				EI 120 - U/C, C/C
PP Pipe 50 mm \emptyset 2.1 mm wall thickness				EI 240 - U/C, C/C
PP Pipe 50 – 110 mm \emptyset 2.1 – 10.7 mm wall thickness*				EI 30 - U/C, C/C
PVC Pipe 40 mm \emptyset 2 mm wall thickness				EI 240 - U/C, C/C
PVC Pipe 114 mm \emptyset 3.6 mm wall thickness				E 90, EI 45 - U/C, C/C
PVC Pipe 114 mm \emptyset 8.1 mm wall thickness				E 120, EI 30 - U/C, C/C
PVC Pipe 40 – 114 mm \emptyset 2 – 8.1 mm wall thickness*				E 90, EI 30 - U/C, C/C

Penetration Service	ASTRO HPE Sealant Depth (mm)	Annular Space (mm)	Backing Material	Classification
PE Pipe 40 mm Ø 4.1 mm wall thickness	≥25 (both sides of floor)	15	≥100mm ≥45 kg/m ³ stone wool	EI 240 - U/C, C/C
PE Pipe 125 mm Ø 7.6 mm wall thickness				EI 60 - U/C, C/C
PE Pipe 125 mm Ø 11.4 mm wall thickness				EI 90 - U/C, C/C
PE Pipe 40 – 125 mm Ø 4.1 – 11.4 mm wall thickness*				EI 60 - U/C, C/C

*Typical pipe diameters shown, see below graph for intermediate sizes

All services supported with pipe and cable supports at 250 mm from upper face of the floor.

PP Pipes - EI 30 U/C

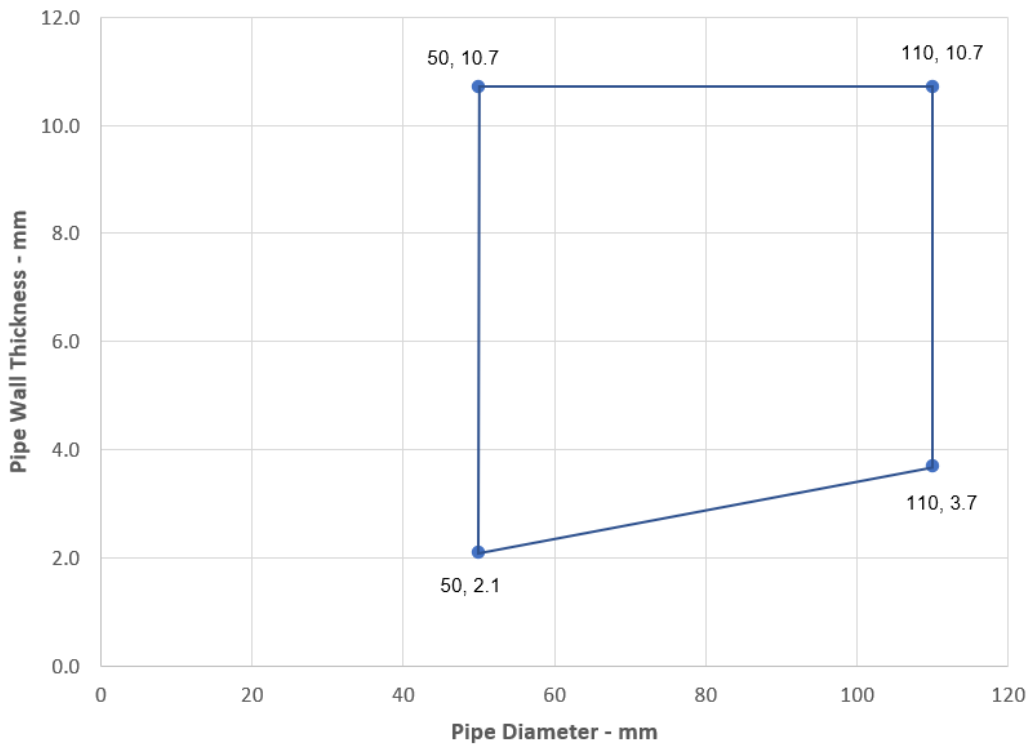

PVC Pipes - E 90, EI 45 U/C

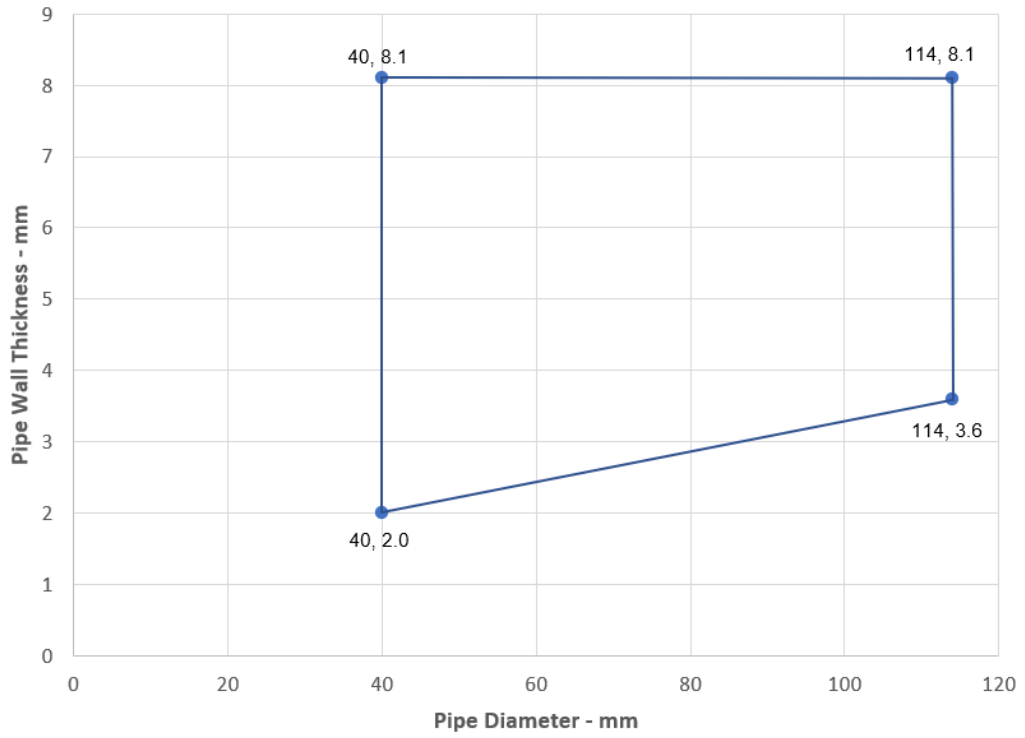

PE Pipes - EI 60 U/C

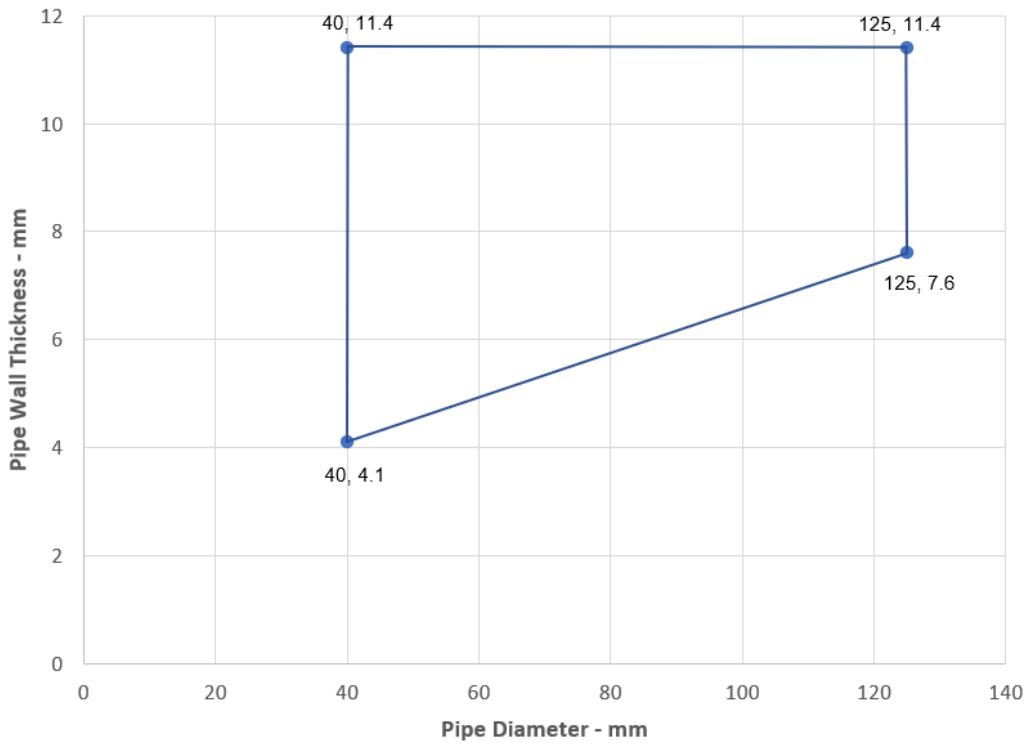

Rigid Floor ≥ 150 mm				
				<p><u>Key</u></p> <ol style="list-style-type: none"> 1. ASTRO HPE Sealant 2. Astro Batt and Coating 3. Plastic pipe 4. Rigid floor
Penetration Service	ASTRO HPE Sealant		50mm Astro Batt and Coating Maximum Aperture Size (mm)	Classification
	Annular Space (mm)	Min. Depth (mm)		
PVC Pipe 50 mm – 125 mm \varnothing 2.6 – 7.4 mm wall thickness*	20	25 - both sides of floor	Double layer 1500 x 1000	EI 60 - U/C, C/C

*Typical pipe diameters shown, see below graph for intermediate sizes

All services supported with pipe and cable supports at 400 mm from upper face of the floor.

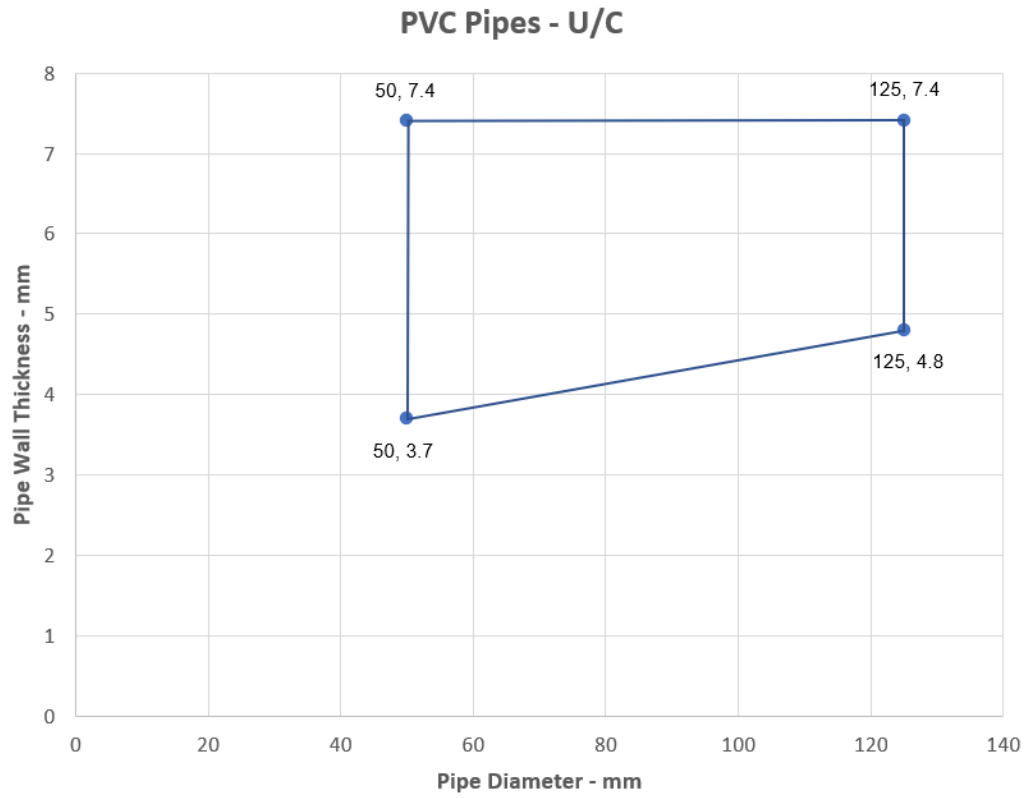

C.4.2 Multi layered pipes

Rigid Floor ≥ 150 mm				
				<p><u>Key</u></p> <ol style="list-style-type: none"> 1. ASTRO HPE Sealant 2. Astro Batt and Coating 3. MLC pipe 4. Rigid floor
Penetration Service	ASTRO HPE Sealant		50mm Astro Batt and Coating Maximum Aperture Size (mm)	Classification
	Annular Space (mm)	Min. Depth (mm)		
Uponor MLC (Multi-Layer Composite) Pipe 40 mm – 110 mm \varnothing 4 mm – 10 mm wall thickness	20	25 - both sides of floor	Double layer 1500 x 1000	EI 60 - U/C, C/C

*Typical pipe diameters shown, see below graph for intermediate sizes

All services supported with pipe and cable supports at 400 mm from upper face of the floor.

MCL Pipes - U/C

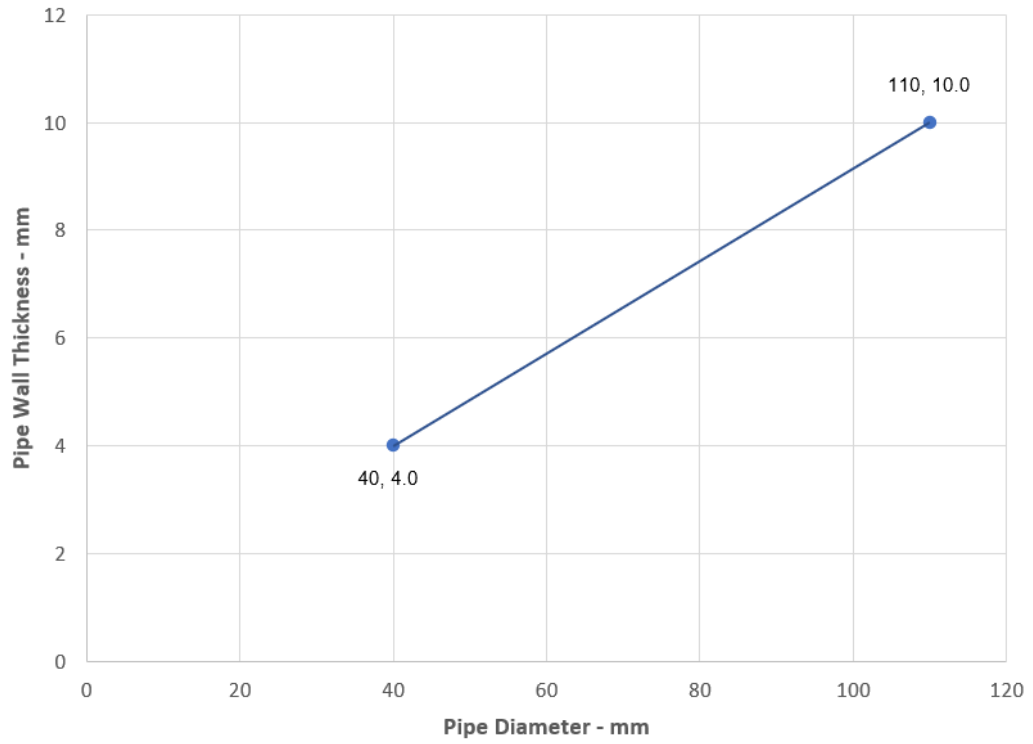

C.4.3 Cables

Rigid Floor ≥ 150 mm				
				<p><u>Key</u></p> <ol style="list-style-type: none"> 1. ASTRO HPE Sealant 2. Backing material 3. Cables 4. Rigid floor
Penetration Service	ASTRO HPE Sealant Min. Depth (mm)	Aperture Size (mm)	50mm Astro Batt and Coating Maximum Aperture Size (mm)	Classification
Electrical Cables ≤ 21 mm \varnothing	≥ 25 (installed upper face only)	Max 200 x 200 Min 50 x 50	≥ 100 mm ≥ 45 kg/m ³ stone wool	E 180, EI 30
Electrical Cables ≤ 80 mm \varnothing				E 120, EI 20
Non sheathed electrical cables 0-24 mm \varnothing				E 180, EI 20

All services supported with pipe and cable supports at 400 mm from upper face of the floor.

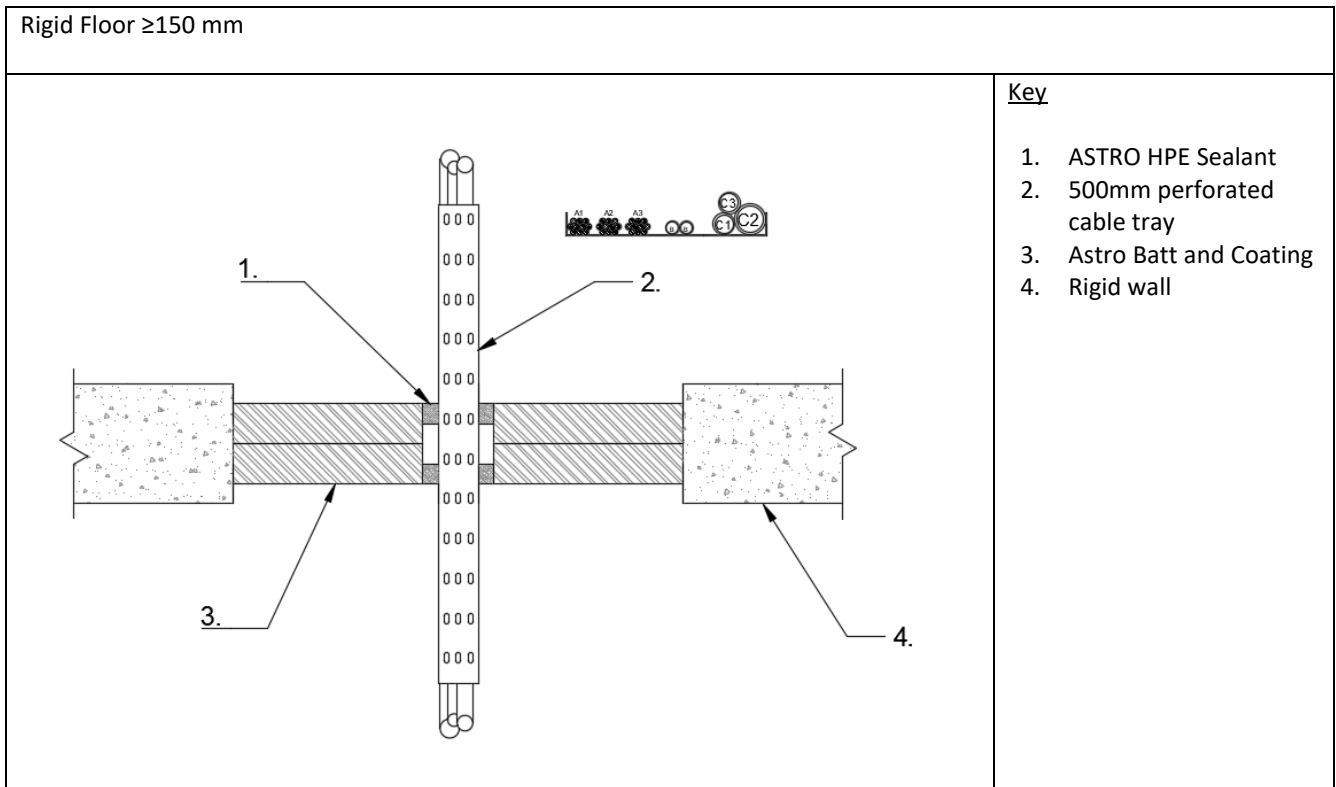

Penetration Service	ASTRO HPE Sealant		50mm Astro Batt and Coating Maximum Aperture Size (mm)	Classification
	Annular Space (mm)	Min. Depth (mm)		
*500 mm perforated cable tray	20	25 - both sides of floor	Double layer 1500mm x 1000	EI 60
*Electrical cables up to 21 mm \varnothing				
*Cable bunch comprising 1no. C1, 1no. C2 and 1no. C3 cables				

*All cables coated with 2 mm DFT PST Coating 300 mm along the cables both sides of the seal

All services supported with pipe and cable supports at 400 mm from upper face of the floor.

C.4.4 Insulated metal pipes

Rigid Floor ≥ 150 mm				
				<p><u>Key</u></p> <ol style="list-style-type: none"> 1. ASTRO HPE Sealant 2. Backing material 3. Copper/Steel pipe 4. Rigid floor
Penetration Service	ASTRO HPE Sealant Min. Depth (mm)	Annular Space (mm)	Backing Material	Classification
Copper/Steel pipe 41-159 mm \varnothing 2.5 mm - 14.2 mm wall thickness, insulated with 13 mm – 32 mm 'Armaflex' (CS) Continued Sustained	≥ 25 (installed upper face only)	20mm	≥ 100 mm ≥ 45 kg/m ³ stone wool	EI 20 - U/C, C/U & C/C
Copper/Steel pipe 41 mm \varnothing 1.4 mm - 14.2 mm wall thickness, insulated with 13 mm 'Armaflex' (CS) Continued	≥ 25 (both sides of floor)			E 240, EI 60 - U/C, C/U, C/C

All services supported with pipe and cable supports at 250 mm from upper face of the floor.